

WindLab Plus Junior

WLP-J

Operating Instructions

This wind turbine (wind power generator) is designed for children to learn the wind power technology. You may use the natural wind or a fan as the source of wind for doing experiment or drive electrical appliances.

Blade parameters of wind turbine are very important to the output power. Blade profiles, lengths, shapes and no. of blades should be adjusted under different wind speed conditions in order to maximize the output power or stall the wind turbine under strong wind speed to protect itself. The LED inside the main body lights up when the generator is generating electricity. Vane will automatically align the generator to the direction of the wind.

This generator operates in two modes, namely "Normal" and "Direct". There are 2 switches ("Normal / Direct" and "1 / 0") to control the output to the DC electrical output connector.

Switch Function		S2	
		Normal	Direct
S1	0	Generated Electrical Energy charges the Gold Capacitor; Gold Capacitor Output to Connector switched OFF	Generated Electrical Energy connected to the Output Connector directly; Generator is not connected to the Gold Capacitor
	1	Generated Electrical Energy charges the Gold Capacitor; Gold Capacitor Output to Connector switched ON	Electrical Energy does not charge the Gold Capacitor; Gold Capacitor Output to Connector switched ON

Schematic Diagram – WindLab Plus

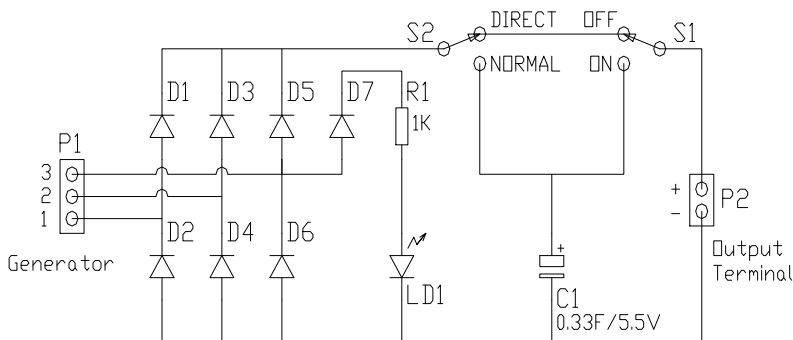

"NORMAL" mode

In "Normal" mode, the generated electricity is to be stored in the Gold Capacitor. The "1 / 0" or "ON / OFF" switch switches the stored electricity to the output connector.

"Direct" mode

In "Direct" mode, the generated electricity is connected to the output connector directly when the "1 / 0" switch is slid to the "0" position. If the "0 / 1" switch is slid to the "1" position, the output connector is connected to the Gold Capacitor and the stored energy can be used. However, the generated electrical energy will neither be stored nor sent to the output connector.

Light and Music Module

A Light & Music Module is included for your evaluation. It has 3 functions, namely Music, Flash LED and Torch LED. Connect the RED and BLACK wire of the module to the RED (+VE) and BLACK (GND) terminals respectively on the DC electrical output connector and observe the results.

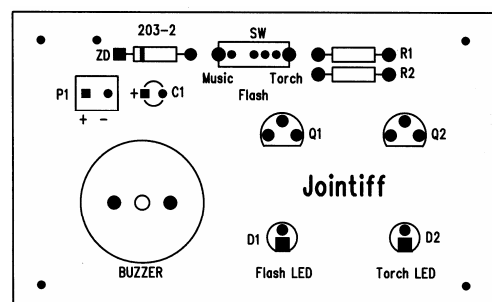

Blade and Vane

Sheet Blades -- They are cut from flexible plastics (Poly-Propylene) sheets. The design concept is to let you design your own blades and vanes with easily available plastic or paper card sheets. Scissors and Punch are the standard stationery needed to work with your imagination to create your own blades and vanes. You can modify the number, size and shape of the blades to see what happens to the output of the DC electricity at the output connector. You may also modify the size, shape and color of the vanes to make fun with it.

Profiled Blades – Profiled blades improve the aerodynamic properties of the wind turbines and the output power is greatly increased. You may use the output to charge rechargeable batteries or electrical appliances.

Features:

- Mini wind turbine (wind power generator)
- Kit for learning wind power technology
- Convert wind energy to DC electrical energy
- Special 3 Phase alternator for high output power
- Rectified DC Output for evaluation and driving electrical appliances
- Gold Capacitor included for storing output from wind turbine
- Visual indication when DC electrical energy is generated
- Vane will automatically align the generator to the direction of the wind
- Blade profile, length, shapes and no. of blades can be evaluated
- Build wind farm or complementary renewable energy system with solar panel

Specification:

- Power Capacity (@ Rotor speed of 2000 rpm) :- 1W
- Direct Output Voltage (@ Rotor speed of 2000 rpm) :- DC 10V
- Direct Output Current (@ Rotor speed of 2000 rpm) :- DC 100 mA
- Start-Up (Rotor start to turn) Wind Speed :- 3.5 mph (1.6 m/s)
- Cut-In (Generator starts to generate electricity) Wind Speed :- 5 mph (2.2 m/s)
- Maximum Output Voltage from Storage Capacitor :- DC 6V
- Length of wind turbines :- 200 mm
- Height (Centre of rotor to Base) of wind turbine :- 280 mm
- Blade sweep radius of Polypropylene Sheet Blade, BS-11, Standard Sheet Blade :- 160 mm
- Blade sweep radius of Polypropylene Sheet Blade, BS-21, Short Sheet Blade :- 110 mm
- Blade sweep radius of Profiled Blade, BP-38 :- 180 mm
- "Direct / Normal" switch to direct Turbine Output to Output Connector or Storage Capacitor
- "1 / 0" switch to select Output from Turbine Output or Storage Capacitor

Turbine	Blade Type	No. of Blade	Wind Speed (mph)	Load (Ohm)	Output Voltage (V)	Output Current (mA)	Output Power (W)	Rotor Speed (RPM)
WindLab Plus	BS-11	3	12	75	4.0	50	0.2	720
WindLab Plus	BP-38	3	12	75	8.0	100	0.8	1440

For more information, please visit www.jointiff.com

Assembly Instructions

Refer to the attached assembly drawings and the Part List reference numbers for assembly. Please note the length of the screws (14) for Rotor, it is 18mm for sheet blade and 20mm for the Profiled Blade.

I. Main Body Assembly

Plug the connector of the generator (10) to the socket on the Printed Circuit Board Assembly (11).

Install the Generator (10), Printed Circuit Board Assembly (11) and the Vane (9) in the Main Body Housing (1 & 2).

Secure the assembly with screws (13) and nuts (16) as shown in the diagram. You may press the 3 nuts (16) to the Left Housing (1) first with the help of the long screw (14).

II. Blade Unit Assembly

Press 3 nuts (16) to the nut holders alternately on the back side of the Blade Base. The Sheet blades are not symmetrical. If the Sheet Blades are installed with the wrong side on top, the Blades will hit the Aluminium Post (7) as the unit rotates. Note this carefully on the drawing for assembly. Install the Blades (8) alternately on the Blade Base (4) and put on the Blade Head (3). Install the 3 screws (14) M2.6 x18mm for Sheet Blades and M2.6 x 20mm for Profiled Blades through the holes on the Blade Head to the nuts (16) on the back side of the Blade Base. Make sure that the screws are aligned with the nuts when you secure the screws.

III. Blade Unit Installation

Plug the Blade Unit to the shaft on the Main Body Assembly. Make sure you press the Blade Unit all the way to the shaft. Check that the Blade Unit is securely clipped to the shaft of the turbine.

(You may also install the Blade Unit after you assemble the Post and Support Base Assembly.)

IV. Post and Support Base Assembly

Install the Aluminium Post on the Support Base Assembly (5) with the Post Secure Pin (6). Install the Body Assembly on the top of the Aluminium Post.

Enable Yawing: secure the screw (15) from the back side of the Body Assembly through the hole in the Aluminium Post into the groove of the plastic stud of the Body Assembly.

Disable Yawing: secure the screw (15) from the front side of the Body Assembly through the hole in the Aluminium Post into the solid plastic stud of the Body Assembly.

Safety

Before you proceed to operate the turbine, please note that the rotor can rotate at a few thousand RPM (Rotations per Minute). Bodily injury may result if struck by rotating blades. You should install the turbine properly so that it will not "walk" or topple over. Placing a rubber mat, polyfoam, or a thin book under the base helps stabilize the turbine if the surface of the table is hard. You may place adhesive tape on the Base Extender to help secure the turbine to a secure surface. In case the turbine topples at high rotational speed, to avoid being hurt, do not try to catch it. Extending the "Base Extender" increases the diameter of the base and reduces the chance of toppling over. Please note that one of the Base Extenders has to be aligned in the direction of vane to prevent it from toppling over. Arranging the wires from the turbine to run inside the aluminium post through the opening on the post and base to external devices prevents the wires from tangling by the rotating blades. All of the above measures help to reduce accidents during operation of the turbine. However, you have to make sure that the environment is safe for doing experiments. Adult supervision is required. This wind turbine is not suitable for children under 12 years old.

Assembly Drawing - Profiled Blade

I. Main Body Assembly

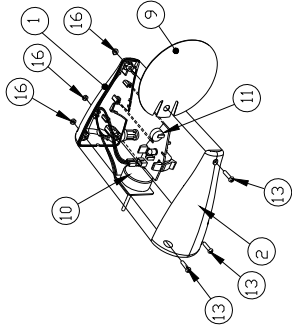

II. Blade Assembly

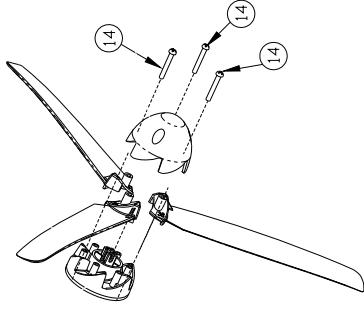

III. Rotor Assembly

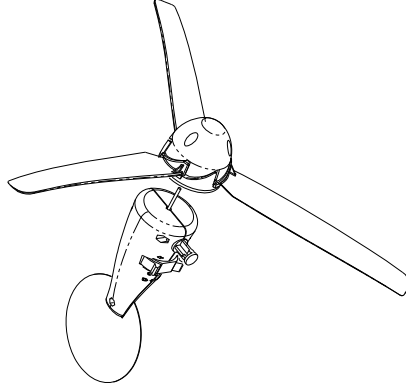

IV. Post and Support Base Assembly

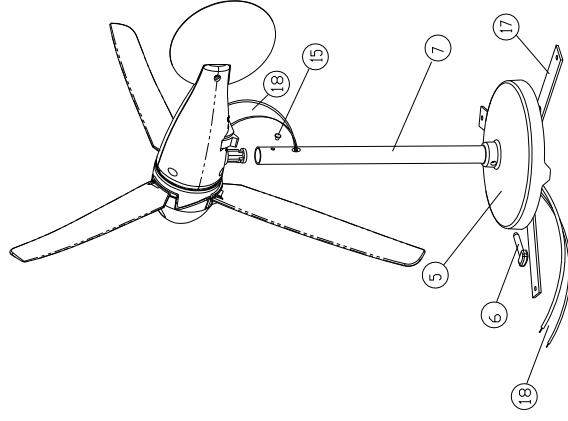

Part List

1. Left Housing
2. Right Housing
3. Blade Head
4. Blade Base
5. Support Base Assembly
6. Post Secure Pin
7. Aluminium Post
8. Moulded Profile Blade
9. Polypropylene Vane
10. Generator
11. Printed Circuit Board Assembly
12. Spring Plate
13. Screw, M2.6 x 10 mm
14. Screw, M2.6 x 20 mm
15. Screw, M3 x 2 mm
16. Hex Nut, M2.6
17. Base Extender
18. Output Wire

Assembly Instruction - Sheet Blade

I. Main Body Assembly

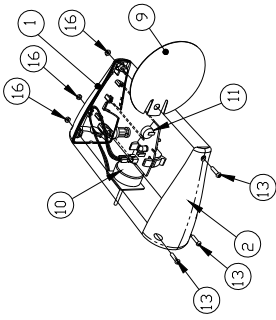

II. Blade Assembly

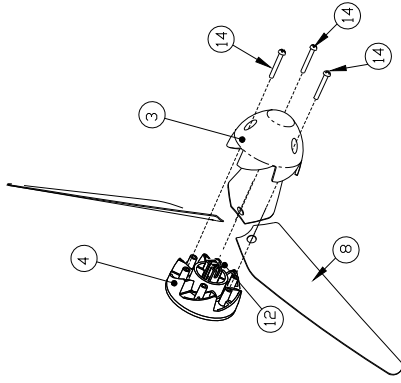

III. Blade Head Assembly

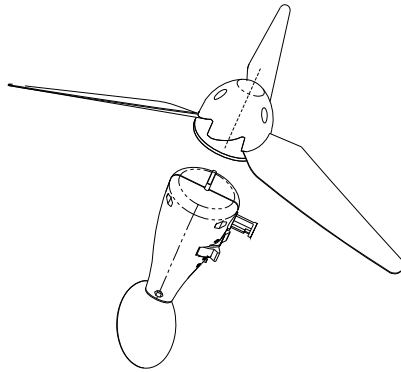

IV. Post and Support Base Assembly

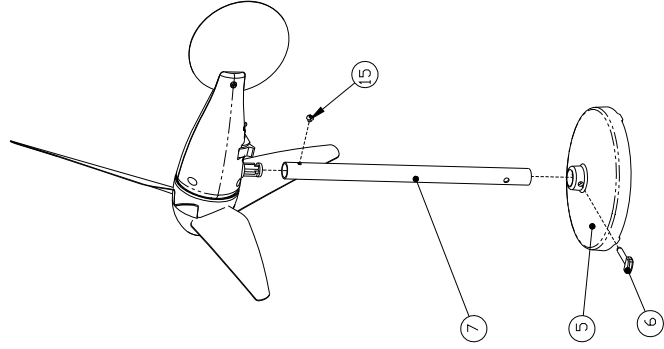

Part List

1. Left Housing
2. Right Housing
3. Blade Head
4. Blade Base
5. Support Base Assembly
6. Post Secure Pin
7. Aluminium Tube
8. Polypropylene Vane
9. Generator
10. Printed Circuit Board Assembly
11. Spring Plate
12. Screw, M2.6 x 10 mm
13. Screw, M2.6 x 18 mm
14. Screw, M3 x 2 mm
15. Hex Nut, M2.6